

2004 Technical Manual



SEPAR FILTER

Marine

The Separ 2000 is a water separator and fuel filter for light diesel fuel. An entirely new multistage centrifugal system ensures a 100% solution to the problem of water and particulate in fuel.



Separ 2000 offers:

- MOST COMPACT DESIGN
- HIGH EFFICIENCY
- LOW FLOW RESTRICTION
- LONG LIFE ELEMENT
- EASY INSTALLATION
- SIMPLE MAINTENANCE



ALGAE-X
Fuel Conditioning

P.O. Box 4011
Fort Myers Beach, FL 33932

info@algae-x.net
www.algae-x.net

Phone: 239-463-0607
Toll Free: 1-877-425-4239

SEPAR 2000

Flow Scheme

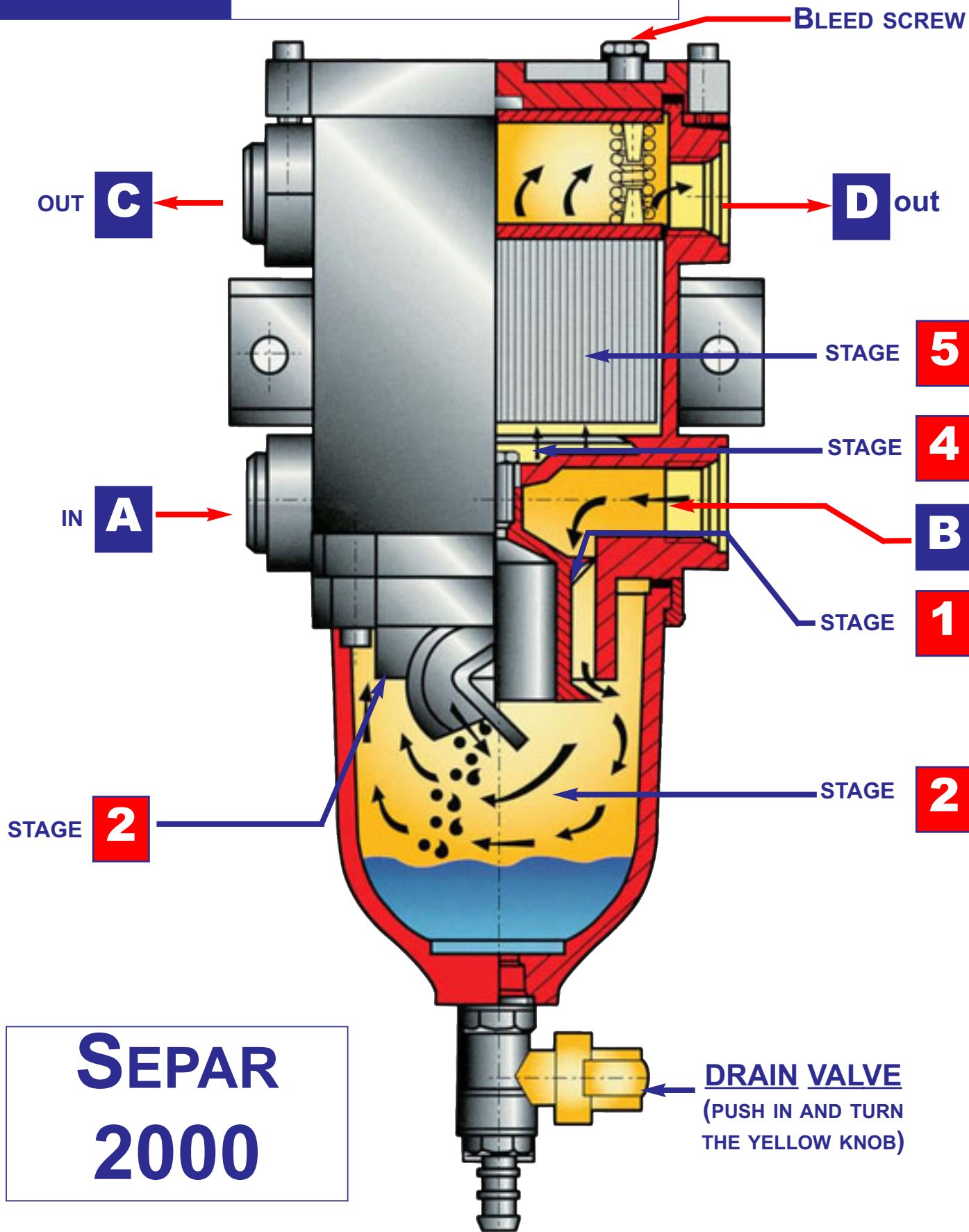

SEPAR 2000

In 1992 Willibrord Losing Filter-Technik designed the next generation of SEPAR Filters called the SEPAR 2000 Series of fuel filters, as an effective system for the separation of water and particulate from fuel. Both water and particulate matter can result in high wear and tear of fuel pumps and injectors, resulting in reduced reliability and expensive engine repairs.

FUNCTIONS OF THE SEPAR 2000

The separation and filtration process takes place according to a new, unique and patented concept, which is applied throughout all of the range. The SEPAR 2000 series is outstanding due its small physical size in relation to the effective flow rate.

The SEPAR 2000 should be installed on the suction side of the fuel system, between the fuel feed tank and the engine mounted fuel lift pump.

Fuel enters the filter through either port A or B depending which is more convenient for installation, and using the plug provided to seal off the unused port.

Stage 1 From the inlet port, fuel flows through the interior vane system which imparts a circular motion to the fuel.

Stage 2 Still in the circular motion fuel reaches the bowl section, where, due to this centrifugal motion water droplets and heavier particles (down to 30 microns in size) are forced to the wall of the bowl, eventually settling in the bottom of the bowl.

Stage 3 In this stage the fuel has to pass the vane system positioned on the "outside" of the central housing. Due to the differing length of the vanes and the twofold rapid change of fuel flow direction, smaller water droplets and finer particles will settle on the vanes. These settlements will agglomerate and when heavy enough fall to the bottom of the bowl. Already at this point the major portion of any contaminants in the fuel have been separated.

Stage 4 Just below the filter element the flow area of the filter is increased significantly thus reducing the fuel flow rate. This calming effect allows even smaller water droplets and particulate to fall out settling on the inner surfaces of the housing, forming larger droplets which eventually fall into the bottom of the bowl by gravity.

Due to the before described pre-separation process, the major portion of water and particulate present in the fuel will be in the bowl or on the inner surfaces of the filter, thus greatly extending the filter element life.

Stage 5 The final filtration of the remaining water and particulate still contained in the fuel will be effected by a replaceable filter element. These filter elements are produced from a special filter media and are available in different pore sizes.

The clean fuel leaves the filter via outlet ports C or D (the outlet port not required should be sealed with the plug provided).

Switch off the engine. Open the bleed valve on top of the filter lid (note: If fuel tank is above the top of the SEPAR filter close the fuel feed valve if fitted) then open the drain valve fitted to the bowl. The clean fuel between the filter lid and the clean side of the element will flush back through the filter element and "wash off" the collected waterdrop-lets and particles from the filter media. At the same time fuel

that is draining from the bowl is carrying contaminants out with it. Close the drain valve open the fuel feed valve and prime the fuel system. Close the bleed valve. Now the engine can be re-started.

If the engine is not able to reach maximum revolutions then the element requires to be replaced.

Switch off the engine. Open the bleed valve on top of the filter lid (note: If fuel tank is above the top of the SEPAR filter close the fuel feed valve if fitted) then open the drain valve fitted to the bowl. The clean fuel between the filter lid and the clean side The SEPAR 2000 can be easily installed. The SEPAR 2000 should be installed on the suction side of the fuel system, between the fuel feed tank and the engine mounted fuel lift pump.



Avoid sharp 90-degree bends on the fuel system piping as these increase system pressure drop, as does any reduction in the internal diameter of fuel piping.



Please use only fittings with o-ring seals (contained in our program of accessories). Do not use hollow bored screws with copper rings as they are difficult to seal and result in a high pressure drop.



Please consider a clear space of 60 mm above the housing/filter lid to replace the filter element.

IMPORTANT:

Only clean diesel fuel should be used to clean the clear plastic bowls, certain cleaning materials can attack the plastic material and have a detrimental effect.

The SEPAR 2000 filters are available in special biodiesel (Cannola) resistant versions on request.

of the element will flush back through the filter element and "wash off" the collected waterdrop-lets and particles from the filter media. At the same time fuel that is draining from the bowl is carrying contaminants out with it. Close the drain valve open the fuel feed valve and prime the fuel system. Close the bleed valve. Now the engine can be re-started.

If the engine is not able to reach maximum revolutions then the element requires to be replaced.



Install the SEPAR 2000 filter in an accessible position. (Any other primary filter has to be removed from the suction line.)



The SEPAR 2000 housing has two inlet and two outlet ports to give options on installation position.



The ideal position for the filter is at the same height as the lift pump. However if the top of the fuel tank is above this position a "full flow" ball valve should be fitted, before the filter so that the fuel flow can be shut off to allow filter maintenance.



In application where the fuel level is below the filter it is still advisable to install a "full flow" ball valve to prevent fuel draining back into the fuel tank.

After filter installation on system without a positive head of fuel, remove the filter lid and fill with fuel to assist in priming the system.

MAIN FEATURES



Available with various flow rates from 1 to 67.5 US gall./min. Thereby offering fuel filters for an engine performance range of 5 to 10,000 kw.



Compact size, various ports, simple installation



High separation efficiency of water which is contained in the fuel. (No water could be proven according to RTÜV testing.)



Due to the backflushing extended service time of the filter elements.



The SEPAR 2000 Filter protects the injection pump and injection nozzles.



Easy maintenance of the SEPAR 2000 filter.

APPLICATION OF THE FILTER



Automotive industry - trucks, busses, mobile cranes, municipality vehicles etc.



Construction equipment, compressor sets, agricultural equipment, fork lift trucks etc.



Marine propulsion



Stationary engines - generators, welding and pumping installations etc.



Mining applications



Special versions for certain applications are available.

MARINE APPLICATIONS



For this purpose switchable filters are available. A water level indication can be supplied optionally.

TEST AND CERTIFICATES



Rheinisch-Westfälischer TÜV



Kraftfahrt-Bundesamt Flensburg



German Technical Department for Army Ship and Marine Weapons



Germanischer Lloyd Type Approval Certificate



Lloyd Type Approval Certificate



Bureau Veritas Type Approval Certificate



RINA

GAS/PETROL APPLICATIONS



For gas/petrol engines special versions are available.

EXTREME TEMPERATURES



For cold ambient temperatures SEPAR 2000 filters are available with an effective heating system.

SEPAR 2000

OPTIONS

FLOW RATES	= Clear bowl	M = Metal bowl
2000/5 = 1.31 Gall./min or 78.6 Gall./H	U = Switchable filter	MK = Metal bowl with contacts
2000/5/50 = 1.31 Gall./min or 78.6 Gall./H		B = Gas/Petrol version clear bowl
2000/10 = 2.63 Gall./min or 157.8 Gall./H	D = Clear bowl with heat shield (RINA-version)	BM = Gas/Petrol version with metal bowl
2000/18 = 4.25 Gall./min or 255 Gall./H	K = Clear bowl with contacts for water level indication	
2000/40 = 10.5 Gall./min or 630 Gall./H	KD = Clear bowl, heat shield, contacts for water level	S = Potentialfree probe for water level indication
2000/130 = 34 Gall./min or 2040 Gall./H		H = Heated filter 12V or 24

SEPAR 2000

Available Versions

SINGLE UNITS	SWITCH. UNITS	DESCRIPTION	US Gal./MIN.	SINGLE UNITS Thread In- and Outlet	SWITCH. UNITS Thread In- and Outlet	SWITCH. UNITS ADAPTORS AVAILABLE
SWK-2000/5	SWK-2000/5/U	Clear bowl	1.31	3/4 x 16 OR Boss	12 mm Pipe Ø	9200-8-12
SWK-2000/5/50	SWK-2000/5/50/U	Clear bowl	1.31	3/4 x 16 OR Boss	12 mm Pipe Ø	9200-8-12
SWK-2000/5/50/K	SWK-2000/5/50/UK	Clear bowl contacts	1.31	3/4 x 16 OR Boss	12 mm Pipe Ø	9200-8-12
SWK-2000/5/50/D	SWK-2000/5/50/UD	Clear bowl heat shield	1.31	3/4 x 16 OR Boss	12 mm Pipe Ø	9200-8-12
SWK-2000/5/50/KD	SWK-2000/5/50/UKD	Clear bowl, contacts, heat shield	1.31	3/4 x 16 OR Boss	12 mm Pipe Ø	9200-8-12
SWK-2000/5/50/M	SWK-2000/5/50/UM	Metal bowl	1.31	3/4 x 16 OR Boss	12 mm Pipe Ø	9200-8-12
SWK-2000/5/50/MK	SWK-2000/5/50/UMK	Metal bowl, contacts	1.31	3/4 x 16 OR Boss	12 mm Pipe Ø	9200-8-12
SWK-2000/5/50/H		Clear bowl, heated filter	1.31	3/4 x 16 OR Boss	12 mm Pipe Ø	9200-8-12
SWK-2000/10	SWK-2000/10/U	Clear bowl	2.63	7/8 x 14 OR Boss	15 mm Pipe Ø	9200-8-15
SWK-2000/10/K	SWK-2000/10/UK	Clear bowl contacts	2.63	7/8 x 14 OR Boss	15 mm Pipe Ø	9200-8-15
SWK-2000/10/D	SWK-2000/10/UD	Clear bowl heat shield	2.63	7/8 x 14 OR Boss	15 mm Pipe Ø	9200-8-15
SWK-2000/10/KD	SWK-2000/10/UKD	Clear bowl contacts, heat shield	2.63	7/8 x 14 OR Boss	15 mm Pipe Ø	9200-8-15
SWK-2000/10/M	SWK-2000/10/UM	Metal bowl	2.63	7/8 x 14 OR Boss	15 mm Pipe Ø	9200-8-15
SWK-2000/10/MK	SWK-2000/10/UMK	Metal bowl contacts	2.63	7/8 x 14 OR Boss	15 mm Pipe Ø	9200-8-15
SWK-2000/10/H		Clear bowl, heated filter	2.63	7/8 x 14 OR Boss	15 mm Pipe Ø	9200-8-15
SWK-2000/18	SWK-2000/18/U	Clear bowl	4.25	1-1/16 x 12 OR Boss	22 mm Pipe Ø	9200-12-22
SWK-2000/18/K	SWK-2000/18/UK	Clear bowl contacts	4.25	1-1/16 x 12 OR Boss	22 mm Pipe Ø	9200-12-22
SWK-2000/18/D	SWK-2000/18/UD	Clear bowl heat shield	4.25	1-1/16 x 12 OR Boss	22 mm Pipe Ø	9200-12-22
SWK-2000/18/KD	SWK-2000/18/UKD	Clear bowl contacts, heat shield	4.25	1-1/16 x 12 OR Boss	22 mm Pipe Ø	9200-12-22
SWK-2000/18/M	SWK-2000/18/UM	Metal bowl	4.25	1-1/16 x 12 OR Boss	22 mm Pipe Ø	9200-12-22
SWK-2000/18/MK	SWK-2000/18/UMK	Metal bowl contacts	4.25	1-1/16 x 12 OR Boss	22 mm Pipe Ø	9200-12-22
SWK-2000/40/M	SWK-2000/40/UM	Metal bowl	10.5	1-5/16 x 12 OR Boss	35 mm Pipe Ø	9200-20-35
SWK-2000/40/MK	SWK-2000/40/UMK	Metal bowl contacts	10.5	1-5/16 x 12 OR Boss	35 mm Pipe Ø	9200-20-35
SWK-2000/40/MS	SWK-2000/40/UMS	Metal bowl probe	10.5	1-5/16 x 12 OR Boss	35 mm Pipe Ø	9200-20-35
SWK-2000/40/2/MK		Metal bowl, contacts	21	42 mm Pipe Ø		9200-24-42
SWK-2000/130/MK	SWK-2000/130/UMK	Metal bowl, contacts	34	2" Pipe	2" Pipe	
SWK-2000/130/MS	SWK-2000/130/UMS	Metal bowl, pot.-free probe	34	2" Pipe	2" Pipe	
SWK-2000/130/2/MK		Metal bowl contacts	68	3" Pipe	3" Pipe	

- **Other versions could be supplied on request**
- **The SEPAR 2000 filter is available with different pore sizes of the filter media**
- **Sizing of the SEPAR 2000 filter: The flow rate l/min of the filter has to be higher than the maximum capacity of engine mounted fuel lift pump.**
- **F.i. Maximum flow rate of the fuel lift pump 8 l/min - corresponding filter SWK 2000/10 with a maximum flow rate of 10 l/min**
- **It is advisable to use switchable filters for marine applications, especially when a vessel is fitted with only one propulsion engine.**

Installation Instructions:

The SEPAR 2000 should be installed on the suction side of the fuel system, between the fuel feed tank and the engine mounted fuel priming pump.

- Install the filter in an accessible position to allow water and particulate removal and filter element change (a minimum of 24" is required for element change).
- The filter housing has two inlet and two outlet ports to give options on installation position.
- The ideal position for the filter is at the same height as the lift pump. However if the top of the fuel tank is above this position a "full flow" ball valve should be fitted, before, the filter so that the fuel flow can be shut off to allow filter maintenance.
- In application where the fuel level is below the filter it is still advisable to install a "full flow" ball valve to prevent fuel drain back into the fuel tank.
- After filter installation on system without a positive head of fuel, remove the filter lid and fill with fuel to assist in priming the system.
- Avoid sharp 90-degree bends on the fuel system piping as these increase system pressure drop, as does any reduction in the internal diameter of fuel piping.
- Check all fittings are tight and free from leaks.

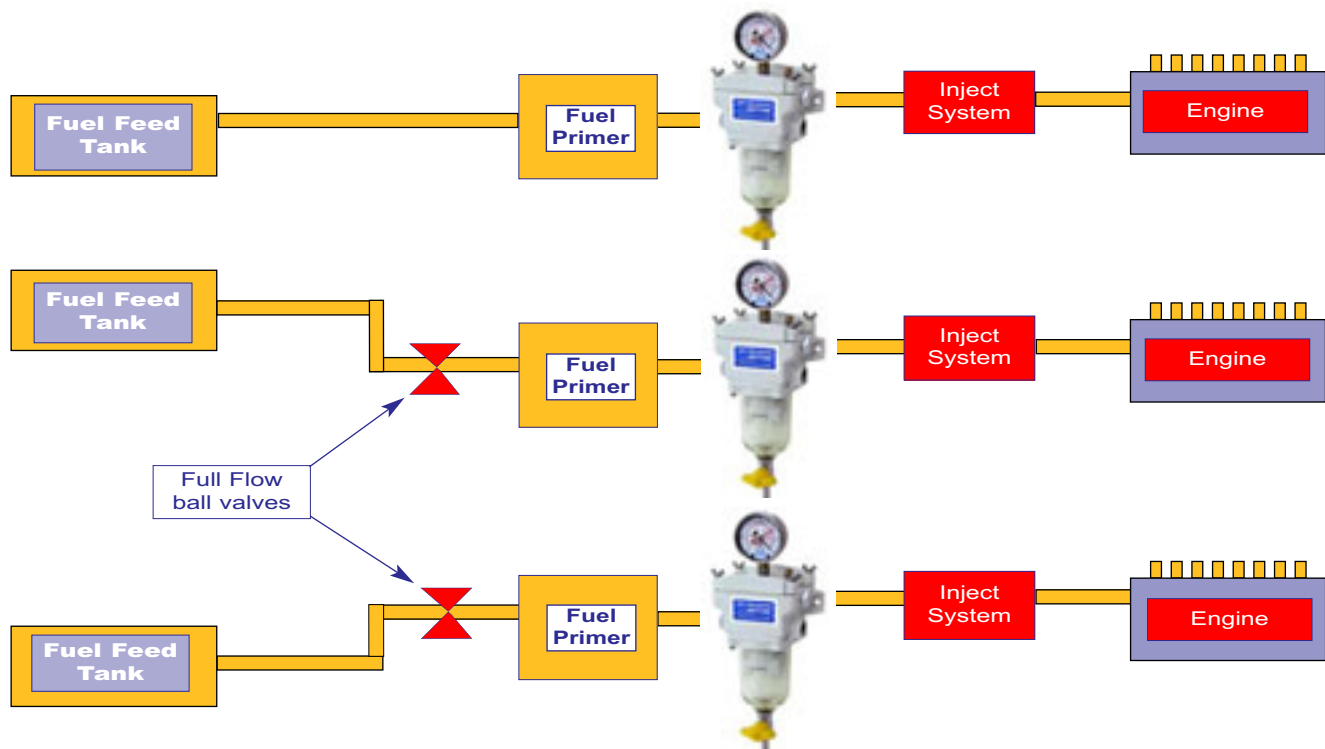

Maintenance Instructions:

- Before any maintenance procedures switch off engine or change over to the other filter if a duplex system is fitted.
- Open bleed valve on top of the filter lid.
- Drain any separated water and particulate by opening the valve push and turn at the bottom of the bowl, then close the drain valve.
- Refill the filter with fuel, by either opening the shut off valve if the fuel level is above the filter or alternatively remove the lid and top up filter, then replace the lid and close the bleed valve.
- Note. Engine mounted fuel lift pumps are normally fitted with a manual priming lever.

The above detailed procedure will have also flushed the filter element by the action of clean fuel washing back down through the element, this action extends the life of the filter element. Replace the filter element of the SEPAR 2000 in the pressure drop is too high or if engine is not able to reach maximum revolutions or at least once a year.

Important: Only clean diesel fuel should be used to clean clear plastic bowls, certain cleaning materials can attack the plastic material and have a detrimental effect

Procedure to replace filter element:

- 1 Stop engine or change to other filter if duplex system
- 2 Loosen the lid screws
- 3 Remove the lid
- 4 Take out the spring cassette
- 5 Lift out filter element by the handle
- 6 Replace with new filter element
- 7 Re-fit the spring cassette
- 8 Check lid gasket is positioned correctly or replace if necessary
- 9 Fit lid checking for correct positioning, insert screws and tighten
- 10 Prime fuel system and check for leaks
- 11 Restart engine or switch to filter of your choice if a duplex system

Spare Elements

FILTER TYPE	SPARE ELEMENT DESCRIPTION	ARTICLE NO.	QUANTITY	SEAL KIT	QUANTITY
SWK 2000/5 SINGLE	PAPER 30 MIC.	00530	1	30969	1
	PAPER 10 MIC.	00510	1		
SWK 2000/5/U DUPLEX	PAPER 30 MIC.	00530	2	30969	2
	PAPER 10 MIC.	00510	2		
SWK 2000/5/50 SINGLE	PAPER 30 MIC.	00530/50	1	30969	1
	PAPER 10 MIC.	00510/50	1		
SWK 2000/5/50/U DUPLEX	PAPER 30 MIC.	00530/50	2	30969	2
	PAPER 10 MIC.	00510/50	2		
SWK 2000/10 SINGLE	PAPER 30 MIC.	01030	1	30970	1
	PAPER 10 MIC.	01010	1		
SWK 2000/10/UDUPLEX	PAPER 30 MIC.	01030	2	30970	2
	PAPER 10 MIC.	01010	2		
SWK 2000/18 SINGLE	PAPER 30 MIC.	01830	1	30979	1
	PAPER 10 MIC.	01810	1		
SWK 2000/18/U DUPLEX	PAPER 30 MIC.	01830	2	30979	2
	PAPER 10 MIC.	01810	2		
SWK 2000/40 SINGLE	PAPER 30 MIC.	04030	1	30980	1
	PAPER 10 MIC.	04010	1		
SWK 2000/40/U DUPLEX	PAPER 30 MIC.	04030	2	30980	2
	PAPER 10 MIC.	04010	2		
SWK 2000/130 SINGLE	PAPER 30 MIC.	01830	4	30993	1
	PAPER 10 MIC.	01810	4		
SWK 2000/130/U DUPLEX	PAPER 30 MIC.	01830	8	30993	2
	PAPER 10 MIC.	01810	8		

SEPAR FILTER

Separ 2000 Comparison Chart

Model: SWK 2000/40MK
Minimum space required for
filter element change

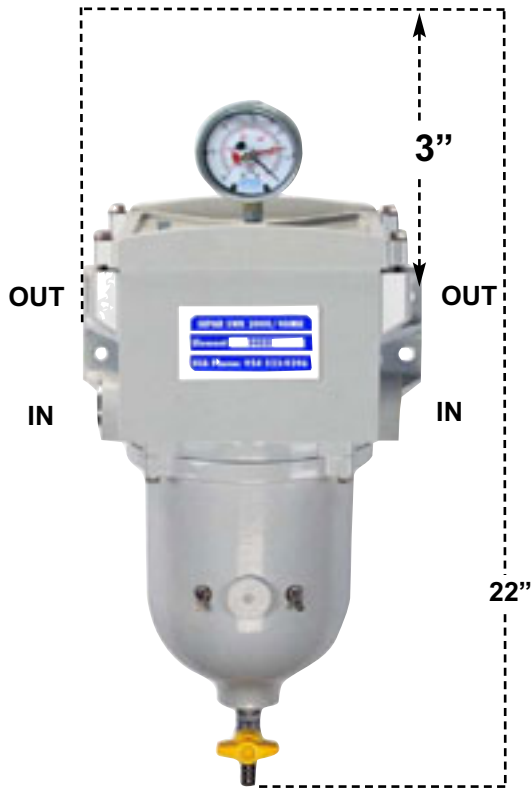

SWK 2000/40MK

- 634 GPH fuel/water separation efficiency = 99.9%
- Minimum free wall space needed
12" W x 22" H x 9" D
- 1 element to change
- 0.95" HG (0.47 PSI) Pressure drop
- Back flushable (Cleanable) element
- 2 (IN & OUT) ports each side

COMPETITOR

Minimum space required for
filter element change

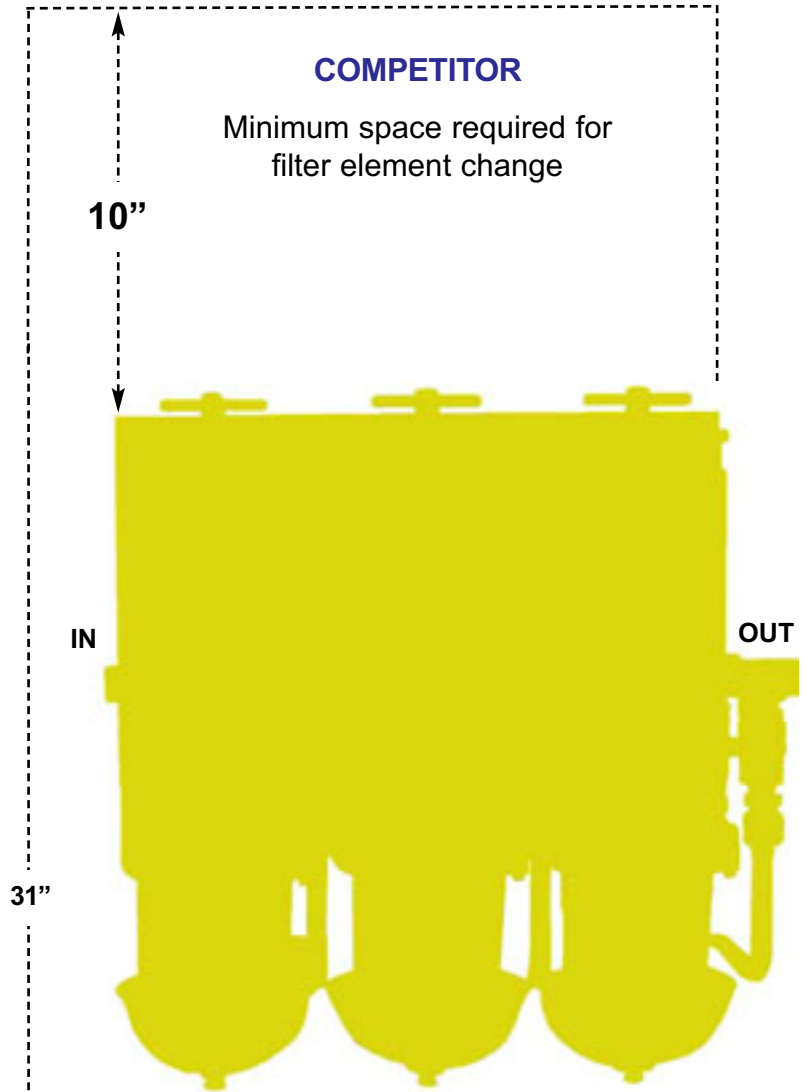

Competitor

- 540 gph fuel/water separation efficiency = unknown
- Minimum free wall space needed
20" W x 31" H x 11" D
- 3 Elements to change
- 5.09"hg (2.5 psi) Pressure drop
- 1 time use elements
- Only 1 (in & out) port on each side

SEPAR FILTER

SWK-2000/5D

MARINE SERIES

Max. Flow Rate: 79 GPH 300 LPH



SWK-2000/5D



SWK-2000/5UD

(Units shown with optional gauge)

Separ 2000 series water separators fuel filters are a simple solution to many different fuel related problems. Five separate stages of filtration ensure 99.9% water separation at max flow. Low restriction reduces wear on fuel pumps and ensures full RPM's. Back flushable (cleanable) element reduces down time and costly element changes.

In Let / Out Let connections

Single Unit: 3/4-16 Straight o-ring **Duplex Unit:** 12 mm. tube (Adaptors available)

FLOW DIAGRAM

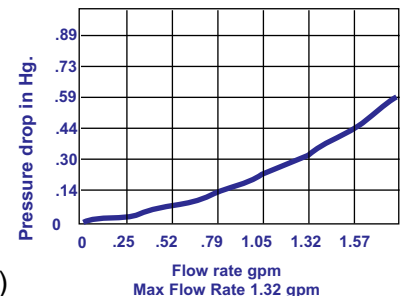

OPTIONS

M = Metal bowl
U = Switchable filter
MK = Metal bowl with contacts

D = Clear bowl with heat shield (U.S.C.G. and R.I.N.A.. Approved)
K = Clear bowl with contacts for water level indication
KD = Clear Bowl, heat shield, contacts for water level

SWK-2000/5D & 2000/5UD

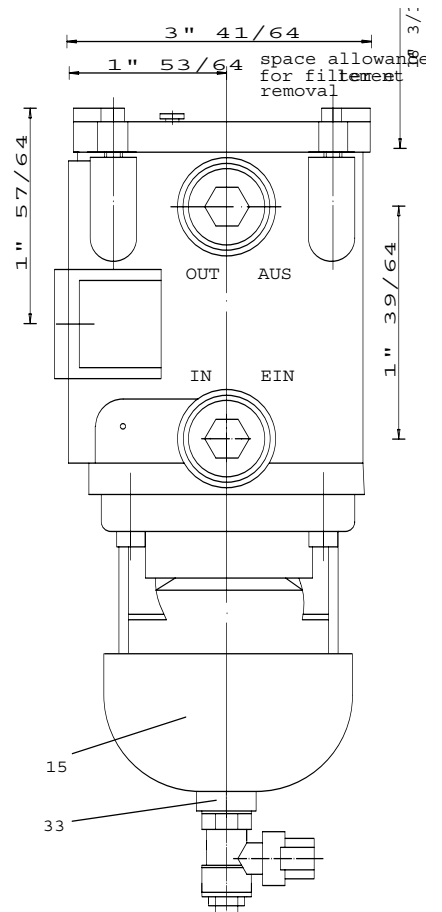
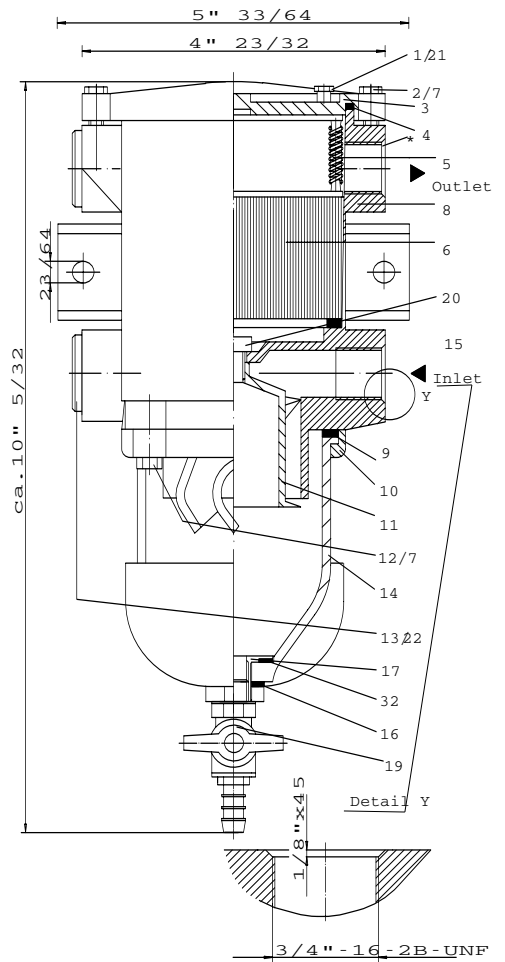
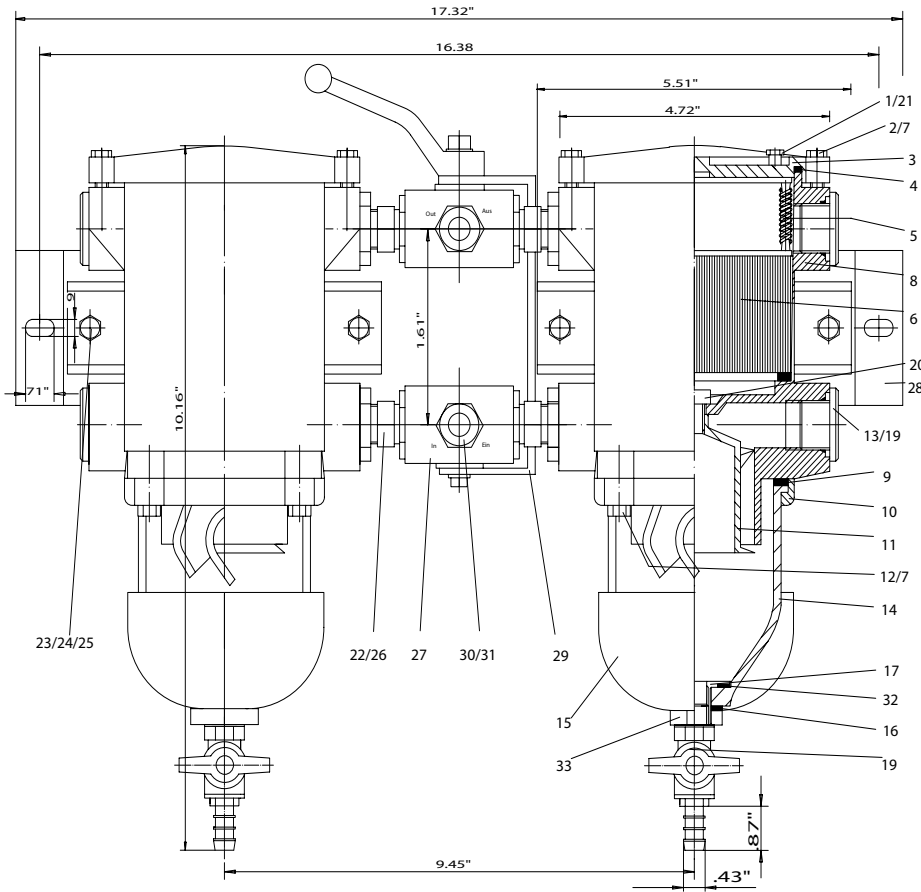

POS	Part Number	Qty	DESCRIPTION	POS	Part Number	Qty	Description
1	30408	1	Bleed Screw	18	40002	1	Drain Valve O-ring
2	FAB-51820	4	Lid Screw	19	30366	1	Drain Valve
3	30542	1	Lid	20	30560	1	Centrifuge Screw
4	30545	1	Lid Gasket	21	30558	1	Bleed Screw Gasket
5	30295	1	Spring Frame	22	30472	1	Blind Screw O-ring
6	00530	1	Filter Element	23	30133	4	Mounting Bracket Screw
7	30447	8	Washer	24	30022	4	Mounting Bracket Lock Nut
8	30408	1	Housing	25	30021	4	Mounting Bracket Washer
9	30565	1	Bowl Gasket	26	30473	4	Straight Fitting
10	30564	1	Retainer Ring	27	30474	1	Reversing Valve
11	30548	1	Centrifuge	28	30475	1	Mounting Bracket
12	30561	4	Bowl Screw	29	30490	1	Reversing Lever
13	6408-08	2	Blind Screw	30	30249	1	Union Nut
14	30959	1	Clear Bowl D-Version	31	30250	1	Cutting Ring
15	30432	1	Heat Shield	32	30151	1	Inner Bowl Gasket
16	30150	1	Outer Bowl Gasket	33	3052-1	1	Bushing Nut
17	30160-1	1	Bushing	34	30652	1	Vacuum Gauge

SEPAR FILTER

SWK-2000/5/50D MARINE SERIES

Max. Flow Rate: 79 GPH 300 LPH



SWK-2000/5/50D



SWK-2000/5/50UD



(Units shown with optional gauge)

Separ 2000 series water separators fuel filters are a simple solution to many different fuel related problems. Five separate stages of filtration ensure 99.9% water separation at max flow. Low restriction reduces wear on fuel pumps and ensures full RPM's. Back flushable (cleanable) element reduces down time and costly element changes.

In Let / Out Let connections

Single Unit: 3/4-16 Straight o-ring **Duplex Unit:** 12 mm. tube (Adaptors available)

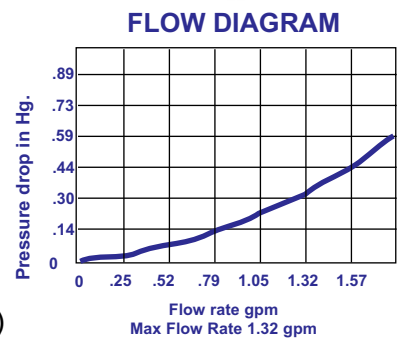

OPTIONS

- M = Metal bowl
- U = Switchable filter
- MK = Metal bowl with contacts

- D = Clear bowl with heat shield (U.S.C.G. and R.I.N.A.. Approved)
- K = Clear bowl with contacts for water level indication
- KD = Clear Bowl, heat shield, contacts for water level



P.O. Box 4011
Fort Myers Beach, FL 33932

info@algae-x.net
www.algae-x.net

Phone: 239-463-0607
Toll Free: 1-877-425-4239

1001305

SWK-2000/5-50D & 5-50 UD

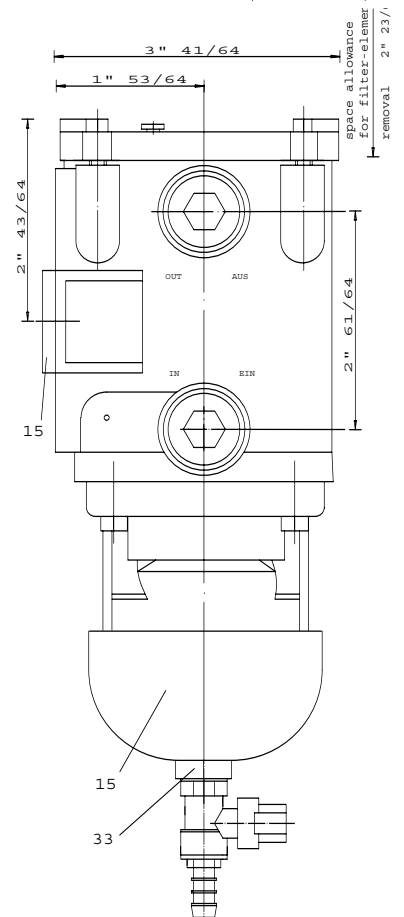
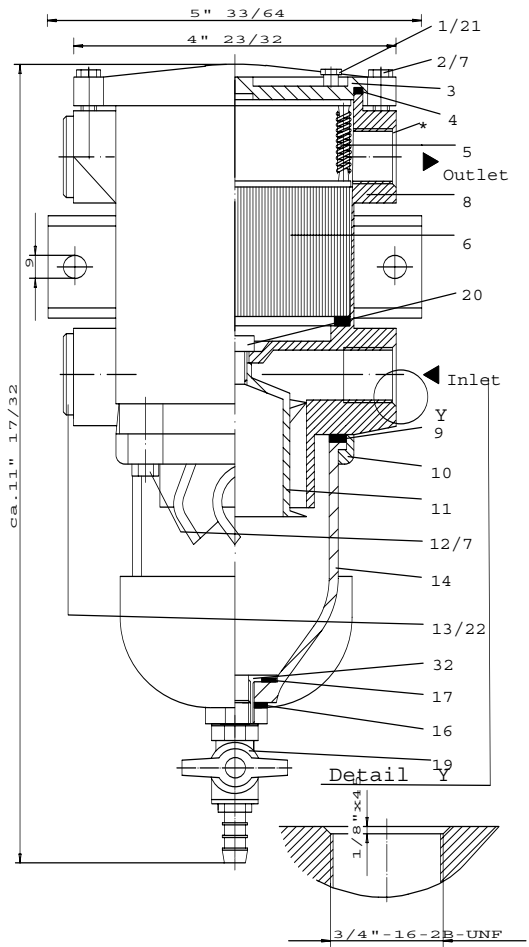
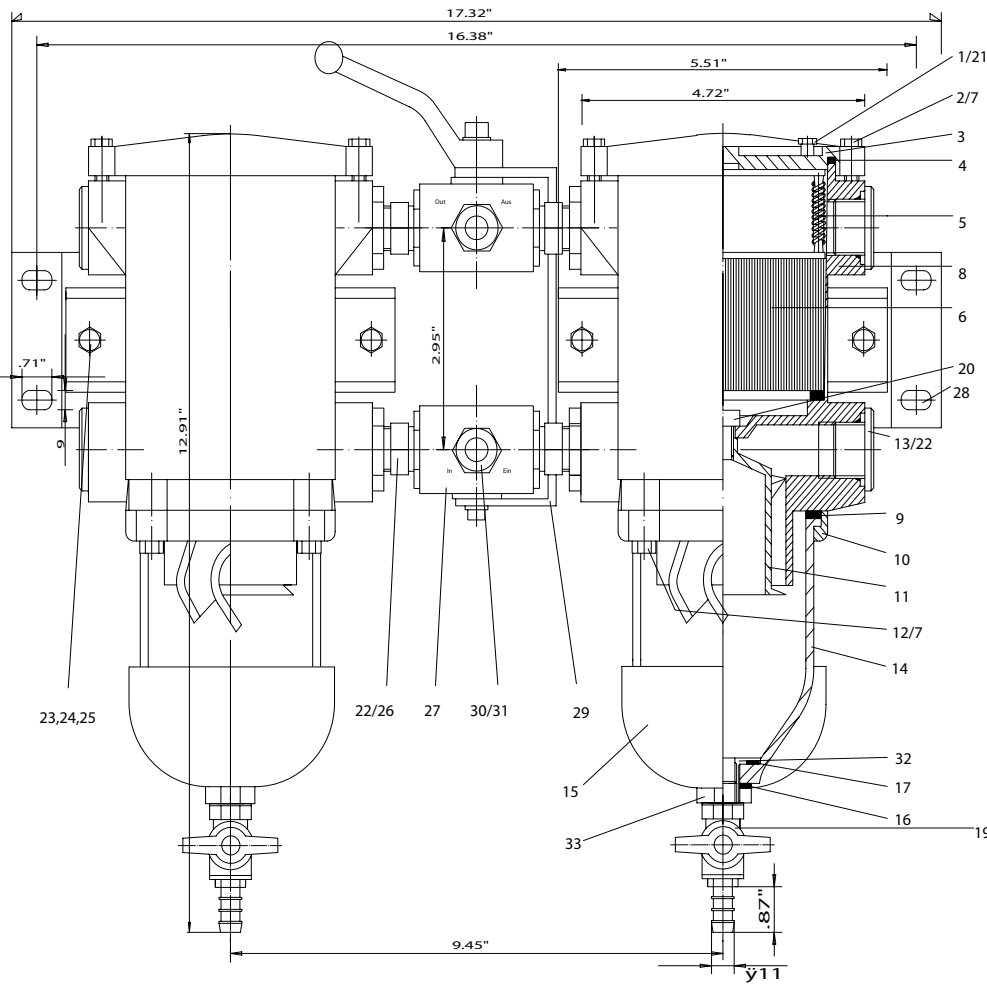

POS	Part Number	Qty	DESCRIPTION	POS	Part Number	Qty	Description
1	30408	1	Bleed Screw	18	40002	1	Drain Valve O-ring
2	FAB-51821	4	Lid Screw	19	30366	1	Drain Valve
3	30542	1	Lid	20	30560	1	Centrifuge Screw
4	30545	1	Lid Gasket	21	30558	1	Bleed Screw Gasket
5	30296	1	Spring Frame	22	30472	1	Blind Screw. O-ring
6	00530/50	1	Filter Element	23	30133	4	Mounting Bracket Screw
7	30447	8	Washer	24	30022	4	Mounting Bracket Lock Nut
8	30541	1	Housing	25	30021	4	Mounting Bracket Washer
9	30565	1	Bowl Gasket	26	30473	4	Straight Fitting
10	30564	1	Retainer Ring	27	30474	1	Reversing Valve
11	30548	1	Centrifuge	28	30475	1	Mounting Bracket
12	30561	4	Bowl Screw	29	30490	1	Reversing Lever
13	6408-08	2	Blind Screw	30	30249	1	Union Nut
14	30959	1	Clear Bowl	31	30250	1	Cutting Ring
15	30432	1	Heat Shield	32	30151	1	Inner Bowl Gasket
16	30150	1	Outer Bowl Gasket	33	30152-1	1	Bushing Nut
17	30160-1	1	Bushing	34	30652	1	Vacuum Gauge

SEPAR FILTER

SWK-2000/10D MARINE SERIES

Max. Flow Rate: 158 GPH 600 LPH



SWK-2000/10D

SWK-2000/10 UD

(Units shown with optional gauge)

Separ 2000 series water separators fuel filters are a simple solution to many different fuel related problems. Five separate stages of filtration ensure 99.9% water separation at max flow. Low restriction reduces wear on fuel pumps and ensures full RPM's Back flushable (cleanable) element reduces down time and costly element changes.

In Let / Out Let connections

Single Unit: 7/8-14 Straight o-ring Duplex Unit: 15 mm. tube (Adaptors available)

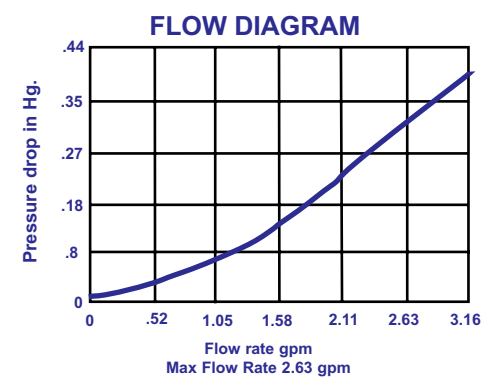

OPTIONS

- M = Metal bowl
- U = Switchable filter
- MK = Metal bowl with contacts

- D = Clear bowl with heat shield (U.S.C.G. and R.I.N.A.. Approved)
- K = Clear bowl with contacts for water level indication
- KD = Clear Bowl, heat shield, contacts for water level



P.O. Box 4011
Fort Myers Beach, FL 33932

info@algae-x.net
www.algae-x.net

Phone: 239-463-0607
Toll Free: 1-877-425-4239

100130D

SWK-2000/10D - 10UD

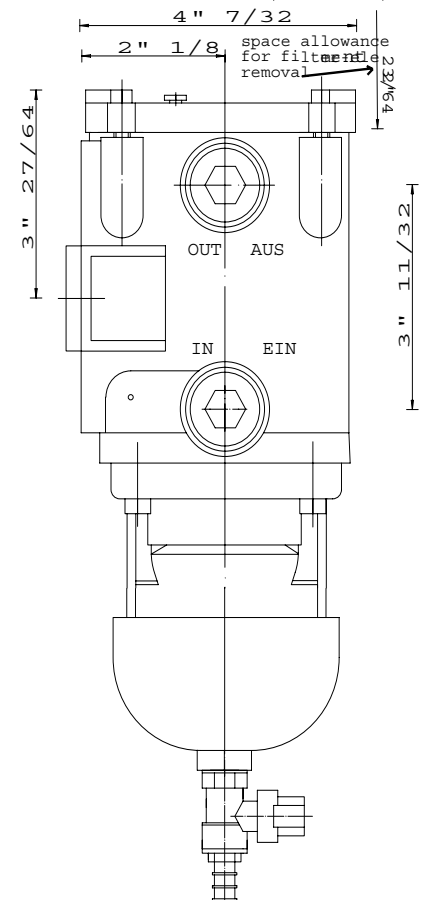
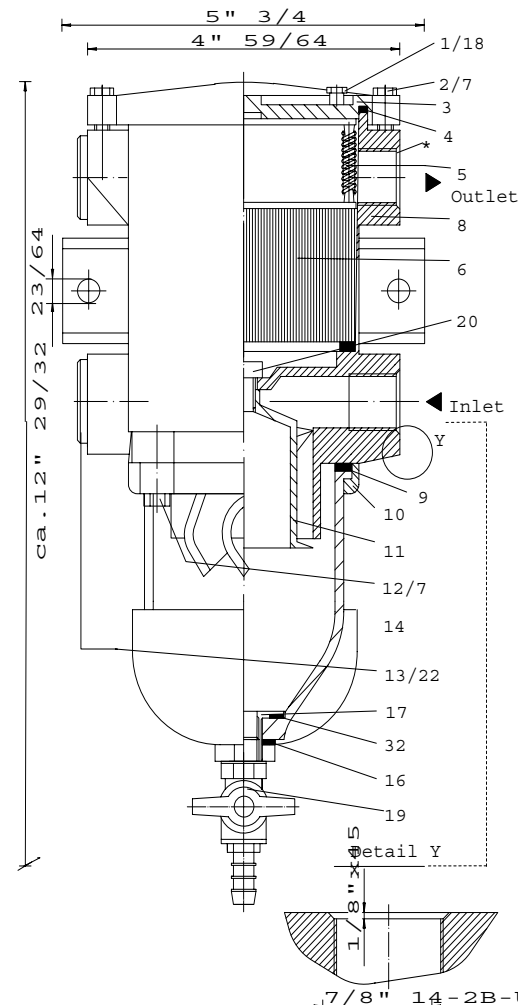
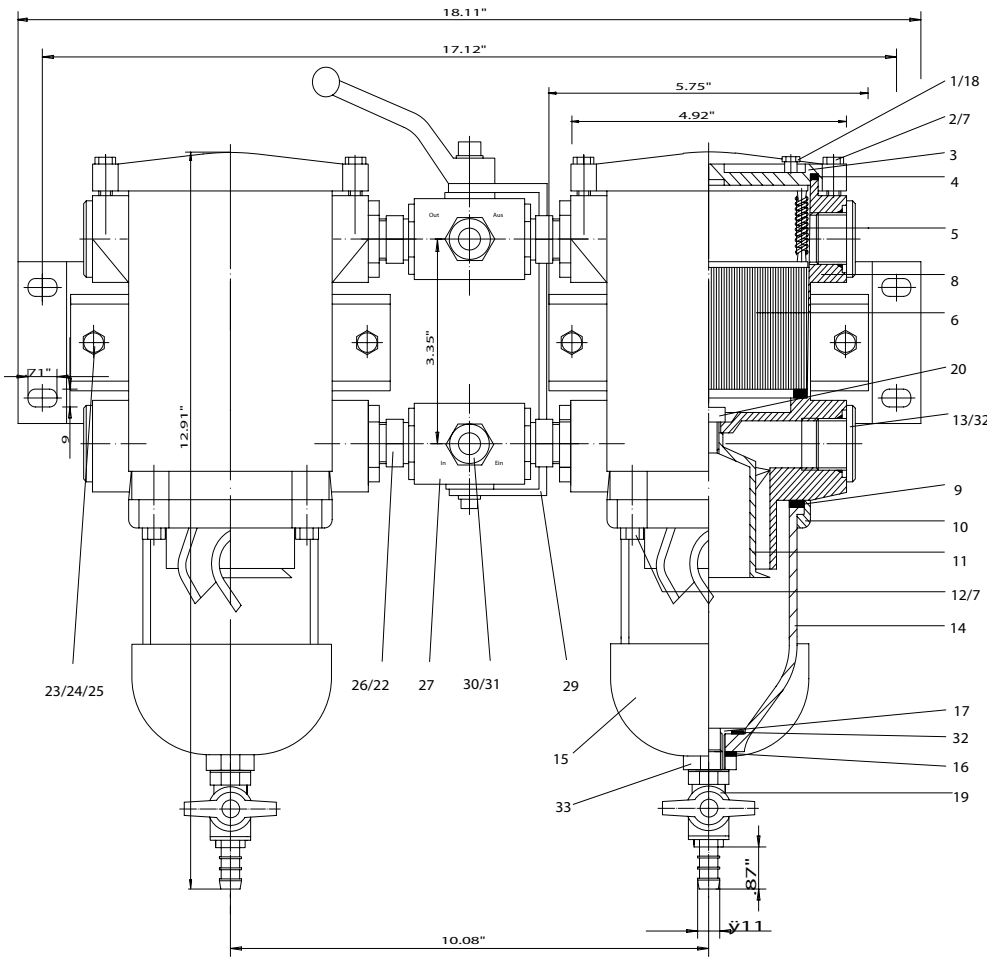

POS	Part Number	Qty	DESCRIPTION	POS	Part Number	Qty	Description
1	30408	1	Bleed Screw	18	40002	1	Drain Valve O-ring
2	FAB-51822	4	Lid Screw	19	30366	1	Drain Valve
3	30553	1	Lid	20	30560	1	Centrifuge Screw
4	30556	1	Lid Gasket	21	30558	1	Bleed Screw Gasket
5	30297	1	Spring Frame	22	40003	1	Blind Screw O-ring
6	01030	1	Filter Element	23	30133	2	Mounting Bracket Screw
7	30448	8	Washer	24	30022	2	Mounting Bracket Lock Nut
8	30552	1	Housing	25	30021	2	Mounting Bracket Washer
9	30576	1	Bowl Gasket	26	30102-1	2	Straight Fitting
10	30569	1	Retainer Ring	27	30476	1	Reversing Valve
11	30563	1	Centrifuge	28	30477	1	Mounting Bracket
12	30568	4	Bowl Screw	29	30491	1	Reversing Lever
13	6408-10	2	Blind Screw	30	30247	2	Union Nut
14	30016	1	Clear Bowl D-Version	31	30248	2	Cutting Ring
15	30433	1	Heat Shield	32	30151	1	Inner Bowl Gasket
16	30150	1	Outer Bowl Gasket	33	3052-1	1	Bushing Nut
17	30160-1	1	Bushing	34	30652	1	Vacuum Gauge

SEPAR FILTER

SWK-2000/18D MARINE SERIES

Max. Flow Rate: 285 GPH 1080 LPH



SWK-2000/18D

SWK-2000/18 UDK

(Units shown with optional gauge)

Separ 2000 series water separators fuel filters are a simple solution to many different fuel related problems. Five separate stages of filtration ensure 99.9% water separation at max flow. Low restriction reduces wear on fuel pumps and ensures full RPM's. Back flushable (cleanable) element reduces down time and costly element changes.

In Let / Out Let connections

Single Unit: 1 1/16-12 Straight o-ring **Duplex Unit:** 22 mm. tube (Adaptor available)

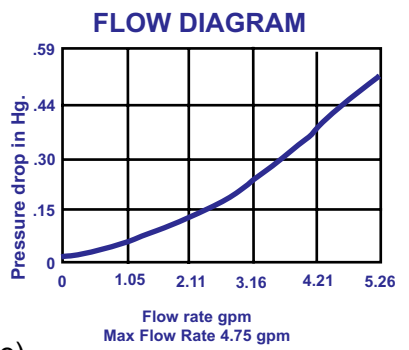

OPTIONS

- M = Metal bowl
- U = Switchable filter
- MK = Metal bowl with contacts

- D = Clear bowl with heat shield (U.S.C.G. and R.I.N.A.. Approved)
- K = Clear bowl with contacts for water level indication
- KD = Clear Bowl, heat shield, contacts for water level



P.O. Box 4011
Fort Myers Beach, FL 33932

info@algae-x.net
www.algae-x.net

Phone: 239-463-0607
Toll Free: 1-877-425-4239

SWK-2000/18D - 18UD

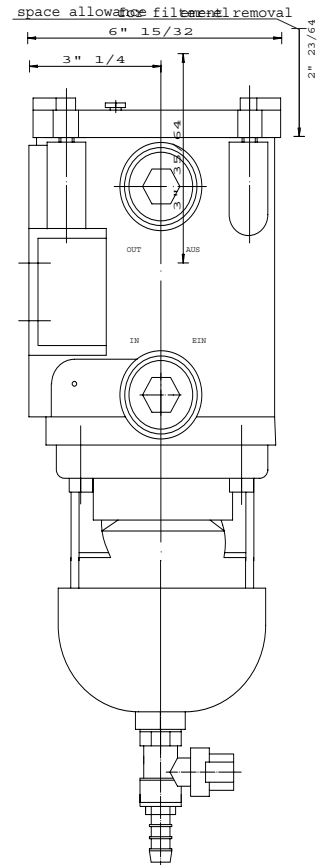
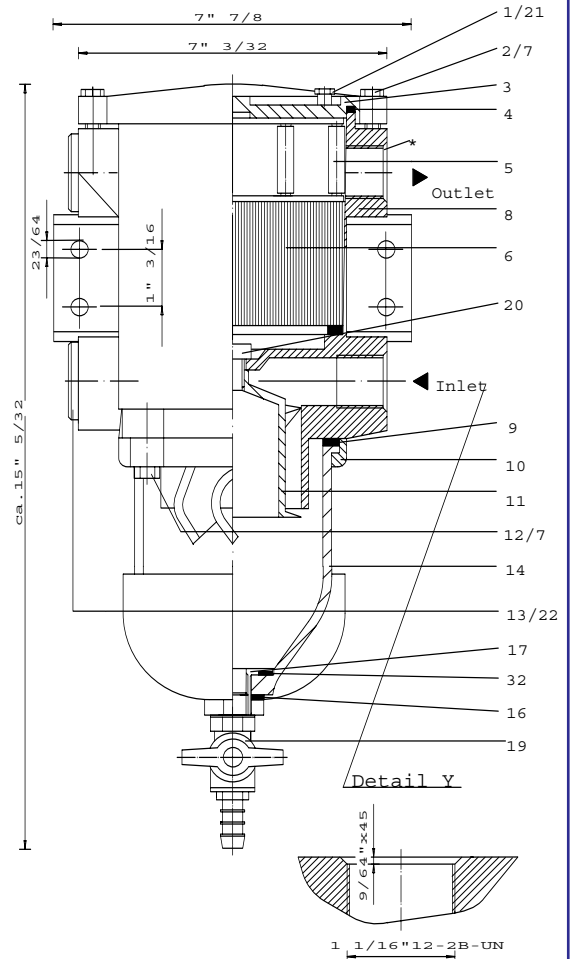
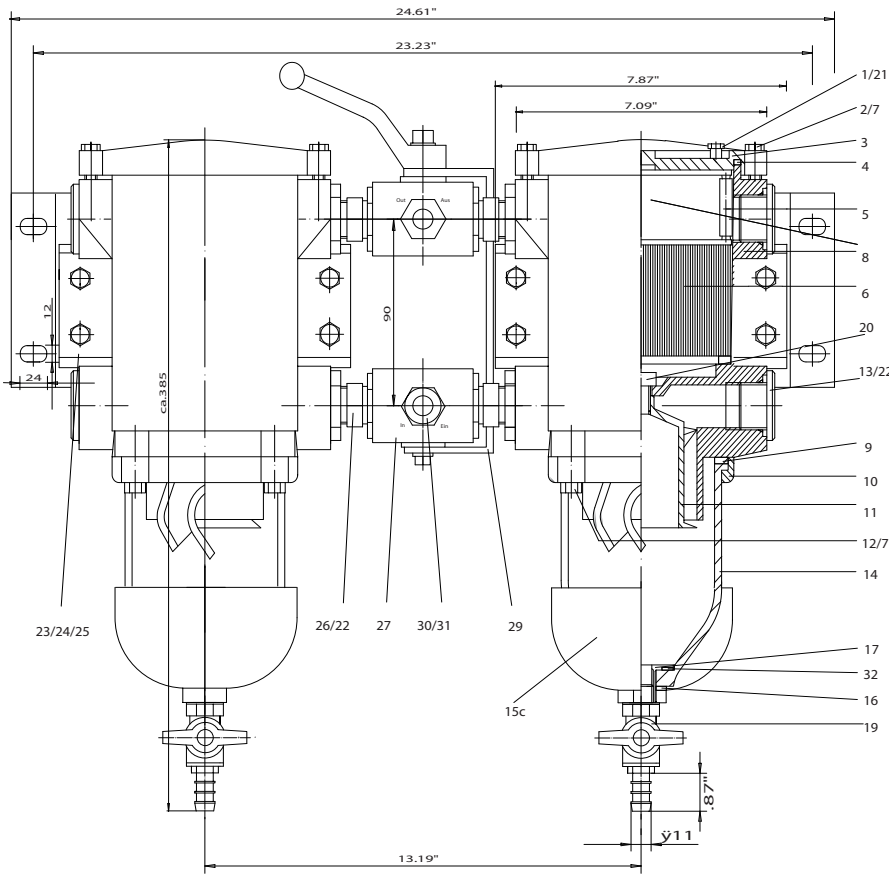

POS	Part Number	Qty	DESCRIPTION	POS	Part Number	Qty	Description
1	30408	1	Bleed Screw	18	30472	1	Drain Valve O-ring
2	FAB-51823	4	Lid Screw	19	30343	1	Drain Valve
3	30572	1	Lid	20	30560	1	Centrifuge Screw
4	30421	1	Lid Gasket	21	30558	1	Bleed Screw Gasket
5	30298	1	Spring Frame	22	30721	4	Blind Screw O-ring
6	01830	1	Filter Element	23	30488	4	Mounting Bracket Screw
7	30448	8	Washer	24	30022	4	Mounting Bracket Lock Nut
8	30428	1	Housing	25	30021	4	Mounting Bracket Washer
9	30423	1	Bowl Gasket	26	30464	4	Straight Fitting
10	30575	1	Retainer Ring	27	30465	1	Reversing Valve
11	30429	1	Centrifuge	28	30466	1	Mounting Bracket
12	30567	4	Bowl Screw	29	30492	1	Reversing Lever
13	6408-12	2	Blind Screw	30	30338	2	Union Nut
14	30037	1	Clear Bowl D-Version	31	30339	2	Cutting Ring
15	3043 ?	1	Heat Shield	32	30151	1	Inner Bowl Gasket
16	30150	1	Outer Bowl Gasket	33	3052-1	1	Bushing Nut
17	30160-1	1	Bushing	34	30652	1	Vacuum Gauge

SEPAR FILTER

SWK-2000/40M

MARINE SERIES

Max. Flow Rate: 630 GPH - 2400 LPH



SWK-2000/40MK

SWK-2000/40 UMK

Separ 2000 series water separators fuel filters are a simple solution to many different fuel related problems. Five separate stages of filtration ensure 99.9% water separation at max flow. Low restriction reduces wear on fuel pumps and ensures full RPM's. Back flushable (cleanable) element reduces down time and costly element changes.

In Let / Out Let connections

Single Unit: 1 5/16 -12 Straight o-ring Duplex Unit: 35 mm. tube (Adaptors available)

OPTIONS

U = Switchable filter

MK = Metal bowl with contacts for water level

FLOW DIAGRAM

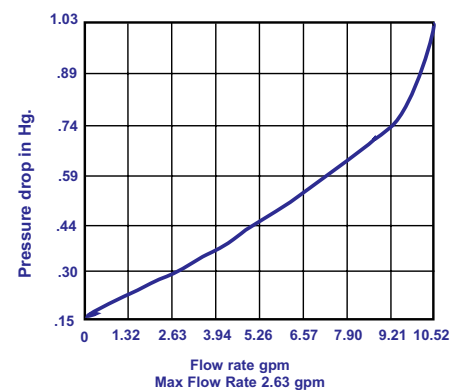

SWK-2000/40MK & 40UMK

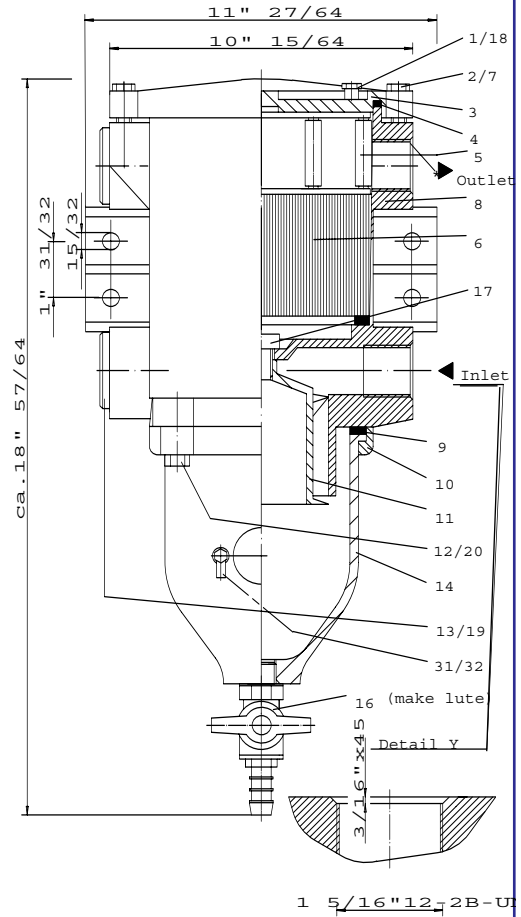
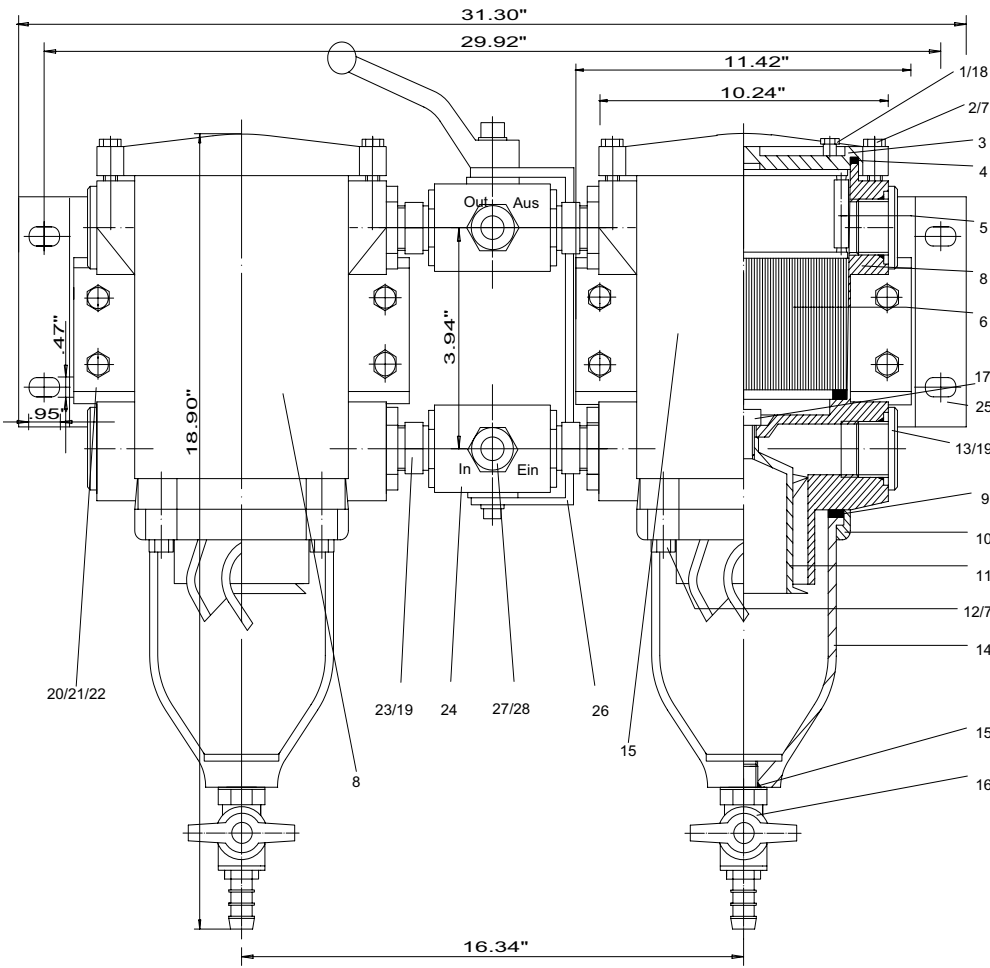

POS	Part Number	Qty	DESCRIPTION	POS	Part Number	Qty	Description
1	30408	1	Bleed Screw	17	30560	1	Centrifuge Screw
2	30404	4	Lid Screw	18	30558	1	Bleed Valve Gasket
3	30435	1	Lid	19	30544	2	Blind Screw O-ring
4	30440	1	Lid Gasket	20	30478	4	Mounting Bracket Screw
5	30299	1	Spring Frame	21	30178	4	Mounting Bracket Lock Nut
6	04030	1	Filter Element	22	30104	8	Mounting Bracket Washer
7	30021	8	Lid Screw Washer	23	30468	4	Straight Fitting
8	10049	1	Right Side Housing	24	30467	1	Reversing Valve
9	30442	1	Bowl Gasket	25	30470	1	Mounting Bracket
10	30446	1	Retainer Ring	26	30493	1	Reversing Lever
11	30438	1	Centrifuge	27	30340	2	Union Nut
12	30567	4	Bowl Screw	28	30341	2	Cutting Ring
13	6408-16	2	Blind Screw	29	30395	4	Gasket
14	30457	1	Metal Bowl	30	30448	4	Bowl Screw Washer
15	10048	1	Left Side Housing	31	30402-9	1	Single Water Contact
16	30456	1	Drain Valve	32	30403-9	1	Dual Water Contact

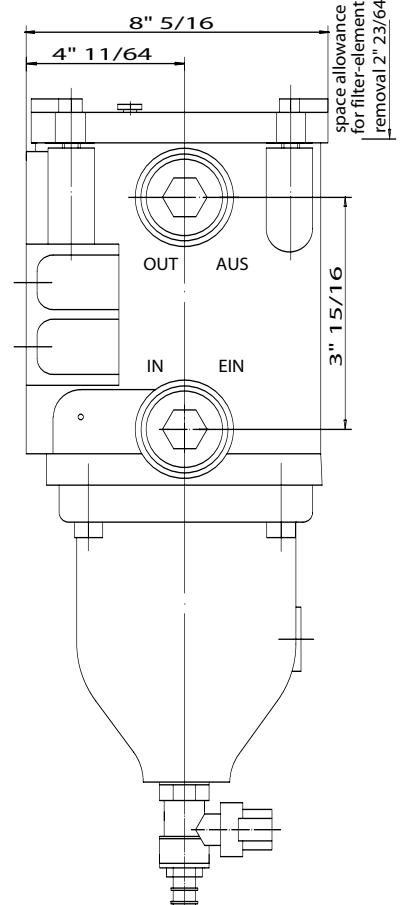

SEPAR FILTER

SWK-2000/130M Marine SERIES

Max. Flow Rate: 2052 GPH - 7800 LPH



SWK-2000/130MK

SWK-2000/130UMK

Separ 2000 series water separators fuel filters are a simple solution to many different fuel related problems. Five separate stages of filtration ensure 99.9% water separation at max flow. Low restriction reduces wear on fuel pumps and ensures full RPM's. Back flushable (cleanable) element reduces down time and costly element changes.

In Let / Out Let connections

Single Unit: 2" NPT Straight o-ring Duplex Unit: 2" NPT tube

OPTIONS

- U = Switchable filter
- MK = Metal bowl with contacts for water level

FLOW DIAGRAM

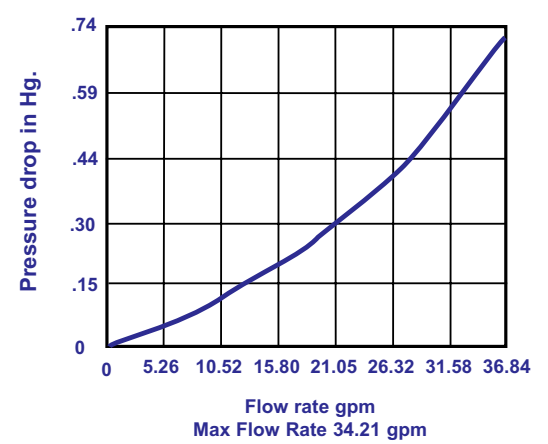

SWK-2000/130MK & UMK

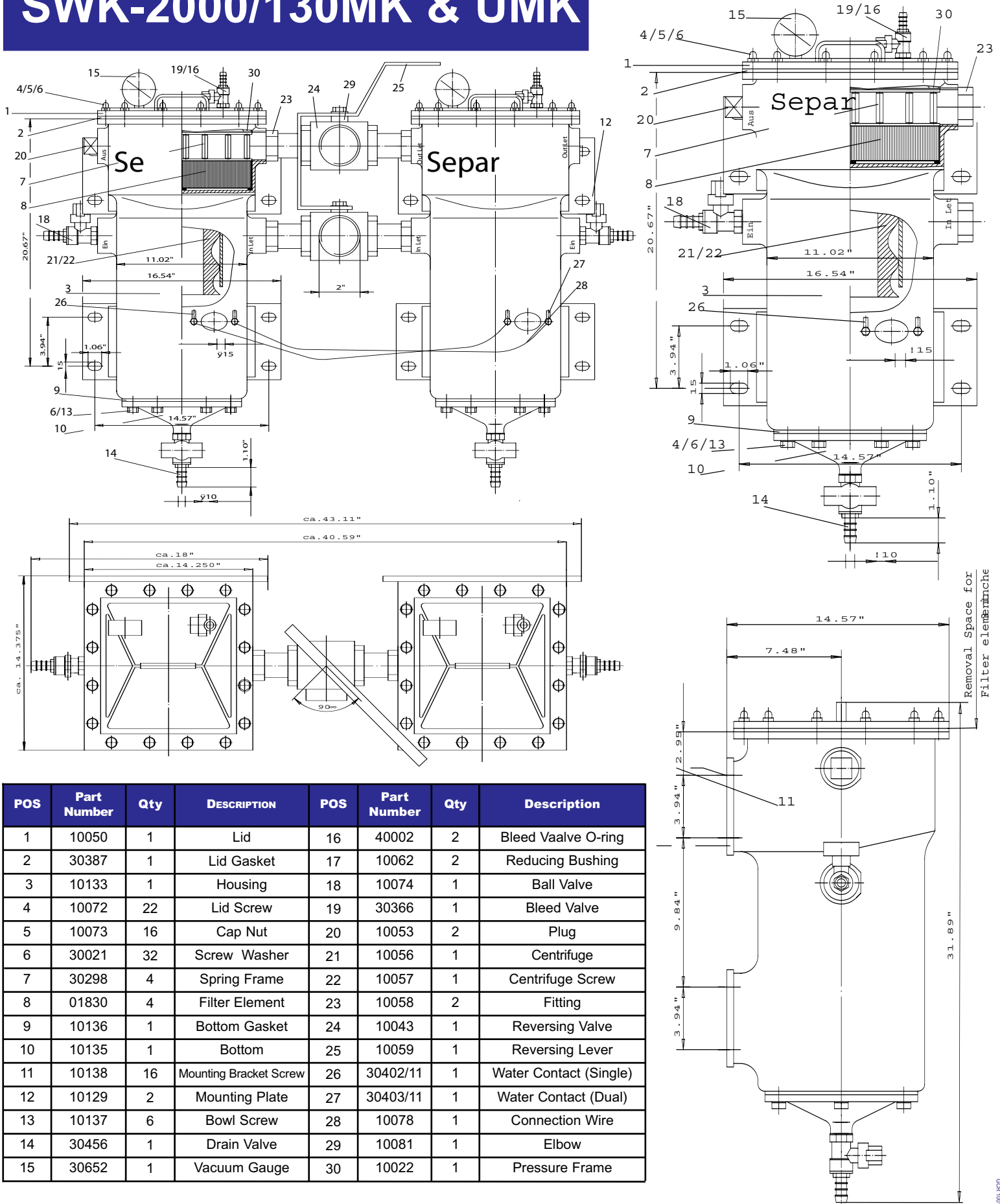

POS	Part Number	Qty	DESCRIPTION	POS	Part Number	Qty	Description
1	10050	1	Lid	16	40002	2	Bleed Vaalve O-ring
2	30387	1	Lid Gasket	17	10062	2	Reducing Bushing
3	10133	1	Housing	18	10074	1	Ball Valve
4	10072	22	Lid Screw	19	30366	1	Bleed Valve
5	10073	16	Cap Nut	20	10053	2	Plug
6	30021	32	Screw Washer	21	10056	1	Centrifuge
7	30298	4	Spring Frame	22	10057	1	Centrifuge Screw
8	01830	4	Filter Element	23	10058	2	Fitting
9	10136	1	Bottom Gasket	24	10043	1	Reversing Valve
10	10135	1	Bottom	25	10059	1	Reversing Lever
11	10138	16	Mounting Bracket Screw	26	30402/11	1	Water Contact (Single)
12	10129	2	Mounting Plate	27	30403/11	1	Water Contact (Dual)
13	10137	6	Bowl Screw	28	10078	1	Connection Wire
14	30456	1	Drain Valve	29	10081	1	Elbow
15	30652	1	Vacuum Gauge	30	10022	1	Pressure Frame